

HZJ & HZJZ Oil Type Testing Transformer



Dear user:

Thank you for choosing HZJ & HZJZ Oil Type Testing Transformer.

We hope that this instrument can make your work easier and more enjoyable, so that you can get the feeling of office automation in the test and analysis work.

Before using the instrument, please read this manual, and operate and maintain the instrument according to the manual to prolong its service life. "Just a light press, the test will be completed automatically" is the operating characteristics of this instrument.

If you are satisfied with this instrument, please tell your colleagues; if you are not satisfied with this instrument, please call (0312) 6775656 to tell you to serve you at all times-Baoding Huazheng Electric Manufacturing Co., Ltd., our company will definitely make you satisfied !

Contents

HZJ & HZJZ Oil Type Testing Transformer..... 1

I.Introduction..... 1

II.Structure..... 1

III.Principle Of Work..... 1

IV.Technical Parameters..... 2

V.Test Wiring..... 4

HZXC HV Hipot Control Unit..... 8

HZTC HV Hipot Control Unit..... 10

I.Outline..... 10

II.Main Characteristics..... 10

III.Panel Introduction..... 11

IV.Technical Parameter..... 12

V.Connection Wire Sketch Drawing Of It And High Voltage Test Transformer..... 12

VI.Manual Explanation..... 13

VII.Usage And Maintenance..... 13

VIII.Supplementary Explanation..... 14

IX.Electrical Schematic Diagram..... 15

Packing List..... 16

HZJ & HZJZ Oil Type Testing Transformer

I.Introduction

The test transformer calls the booster, it is the basic test equipment used by the power station, supplying and distributing the electrical power system and the scientific research unit. Which used in the insulated intension test on all kinds of electrical products, electrical equipments and insulated materials, testing the insulated level of products, discovering the insulated objection of quizzee, scaling the capacity burdened voltage.

II.Structure

They make up of the high quality cold rolling silicon steel piece by HZJ alternating current test transformer, HZJZ alternating and direct current amphibious light high voltage test transformer. The winding is the concentric pagoda and multilayer cylindrical type, low-voltage winding in inner, high-voltage winding in outside; Outer cover is portable which has characteristics, such as volume smallness, weight light, the shape prettiness and move convenience and so on.



III.Principle Of Work

Connecting the control unit (it is the supplementary equipment of test transformer, detailed see the explaining book) with work frequency 220V (above 10KVA with 380V), adjusting 0-220V/380V voltage input to HZJ (HZJZ) test transformer primary winding through autotransformer. According to the principle of electromagnetic influence, the secondary (high voltage) winding may gain the same multiple voltage value than the primary winding with the circle rated that is the high frequency voltage of work frequency. It can obtain the direct current high frequency voltage after commuted by high frequency voltage silicon stack and filtrated by capacitor, among whose amplitude value is the 2 times value of work frequency.

This series product divides into three kinds: the alternating current is named YDJ, the alternating and direct current is named as HZJZ, meanwhile, may connecting HZJ, HZJZ with 200V switch to form series excitation transformer.

IV. Technical Parameters

1. Technical parameters of HZJ series alternating current test transformers.

Model	Capacity (KVA)	High Frequency Voltage Output Voltage (KV)	High Frequency Voltage Output Current (mA)	Low Frequency Voltage input		Ratio	Tempera- ture(°C) raised/ 30 minute
				V	A		
HZJ-1.5	1.5	50	30	200	7.5	500	10
HZJ -3	3	50	60	200	15	500	10
HZJ -5	5	50	100	200	25	500	10
HZJ -10	10	50	200	220/380	50/26	500	10
HZJ -20	20	50	400	380	53	500	10
HZJ -30	30	50	600	380	79	500	10
HZJ -40	40	50	800	380	105	500	10
HZJ -50	50	50	1000	380	132	500	10
HZJ -5	5	100	50	200	25	1000	10
HZJ -10	10	100	100	200/380	50/26	1000	10
HZJ -20	20	100	200	380	53	1000	10
HZJ -30	30	100	300	380	79	1000	10
HZJ -40	40	10	400	380	105	1000	10
HZJ -50	50	100	500	380	132	1000	10
HZJ -100	100	100	100	500	263	1000	10
HZJ -150	150	15	10	400	375	1000	10
HZJ -200	200	100	2000	500	400	1000	10
HZJ -250	250	100	2500	380	500	1000	10

HZJ -20	20	150	133	380	53	1500	10
HZJ -30	30	150	200	380	79	1500	10
HZJ -50	50	150	333	380	132	1500	10
HZJ -100	100	150	666	500	263	1500	10
HZJ -150	150	150	1000	500	300	1500	10
HZJ -200	200	150	1333	500	400	1500	10
HZJ -250	250	150	1666	380	500	1500	10
HZJ -30	30	200	150	380	79	2000	10
HZJ -50	50	200	250	380	132	2000	10
HZJ -100	100	200	500	380	263	2000	10
HZJ -150	150	200	750	500	300	2000	10
HZJ -200	200	200	1000	500	400	2000	10
HZJ -250	250	200	1250	500	500	2500	10
HZJ -30	30	250	120	380	79	2500	10
HZJ -50	50	250	200	380	132	2500	10
HZJ -100	100	250	400	380	263	2500	10
HZJ -150	150	250	600	500	300	2500	10
HZJ -200	200	250	800	500	400	2500	10
HZJ -250	250	250	1000	500	500	2500	10

Note: 100KVA and the above input voltage may enhance to 3000V or proposed by the users.

2. Technical parameters of HZJZ alternating and direct current test transformers.

Model	Capacity (KVA)	High Frequency Voltage Output (KV)		High Frequency Voltage Current (Ma)		Low pressure input		Ratio	Tempera- ture(°C) raised/ 30 minute
		AC	DC	AC	DC	V	A		

HZJZ -1.5	1.5	50	70	30	15	200	7.5	500	10
HZJZ-3	3	50	70	60	15	200	15	500	10
HZJZ -5	5	50	70	100	15	200/380	25	500	10
HZJZ-10	10	50	70	200	100	380	50/26	500	10
HZJZ -20	20	50	70	400	100	380	53	500	10
HZJZ-30	30	50	70	600	100	380	79	500	10
HZJZ -40	40	50	70	800	100	380	105	500	10
HZJZ-50	50	50	70	1000	100	380	132	500	10
HZJZ -5	5	100	140	100	50	200/380	25	1000	10
HZJZ -10	10	100	140	200	100	380	50/26	1000	10
HZJZ-20	20	100	140	300	100	380	53	1000	10
HZJZ -30	30	100	140	400	100	380	79	1000	10
HZJZ -40	40	100	140	600	100	380	105	1000	10
HZJZ -50	50	100	140	1000	100	380	132	1000	10

V.Test Wiring

1. Wiring schematic drawing of the alternating current (work frequency) pressure test.

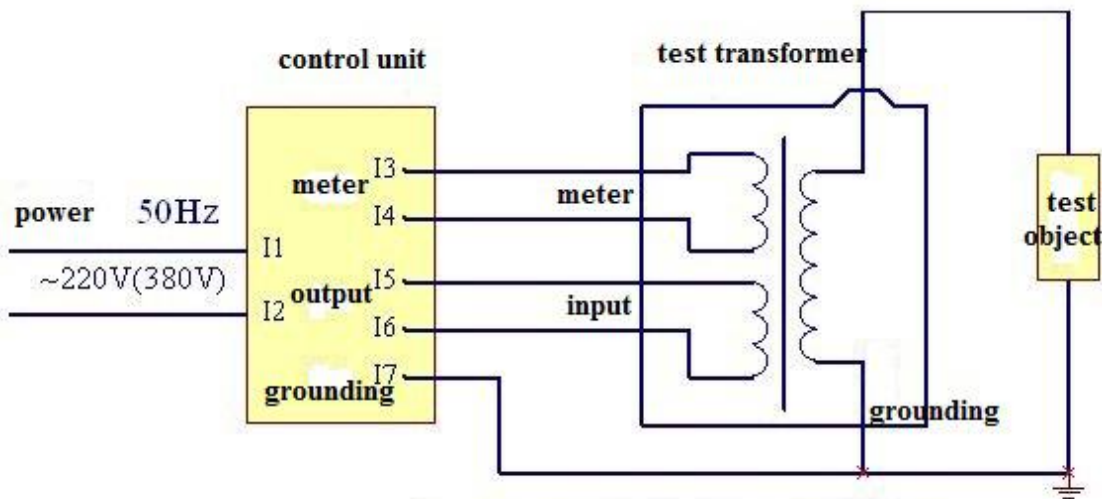

Explanation:

Carrying through the alternating current pressure test, it does not only use the HZJ test

transformer, but also the HZJZ test transformer. But, when performing the alternating current pressure test, don't pull out the short circuit pole on the high compression leg.

2. Wiring schematic drawing of direct current leak and direct current pressure test.

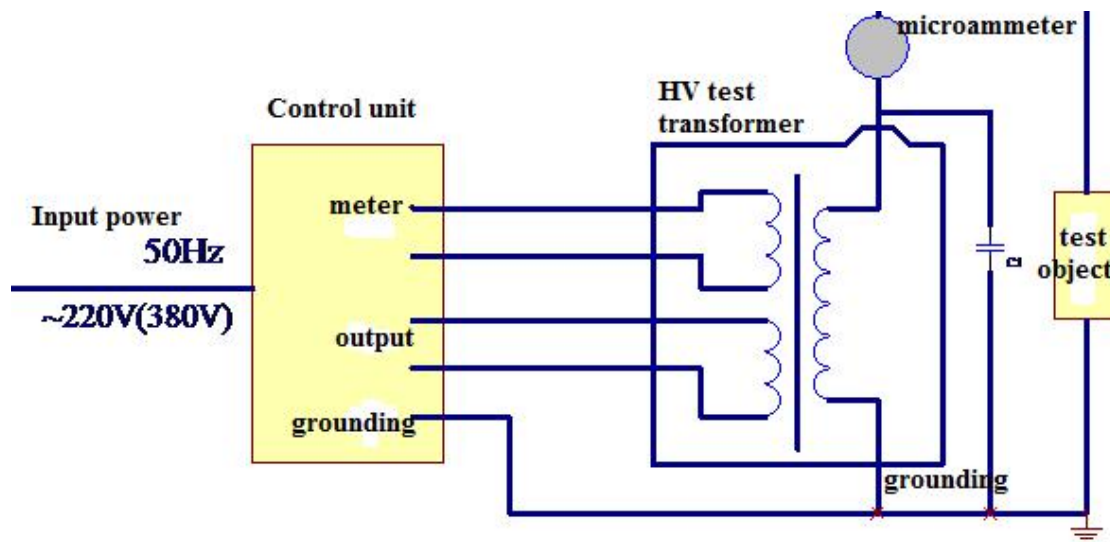

Explanation:

2.1. Engage in the direct current leak and direct current pressure test, it should only use the HZJZ test transformer and pull out the short circuit pole worked on the high compression leg.

2.2 When do the electric cable pressure, not to combination capacitance in stead of potentiometer , it should read value of the high pressure voltage exactly and it is very intuitionistic.

2.3 When the direct current is leaked, the microampere meter may direct readout the value of the direct current pressure test.

2.4 Complete the direct current leak, may carry out direct current pressure test directly without taking out stitches.

2.5 Need to add capacitance when doing arrester test.

3. Series Excitation Combination Test Transformer Wiring.

3.1 When carry out alternating current series high frequency voltage test transformer, may form test transformer with high voltage compounding a few set of HZJ . This principal is

that HZJ high frequency voltage winding is connected with the excitation winding, and make their parameter the same with the next-step primary winding.

3.2 Schematic drawing of two set of HZJ series excitation test transformers.

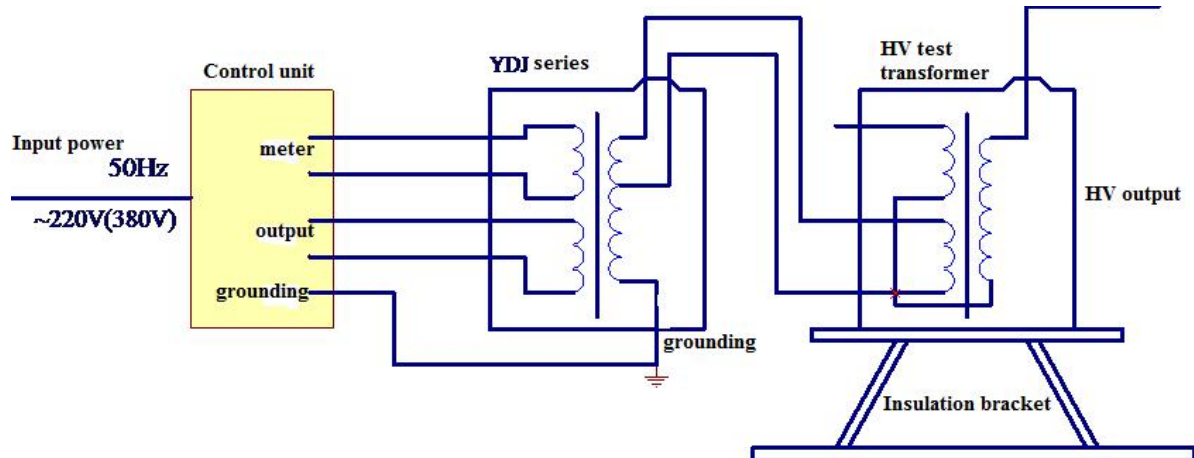

3.3 Schematic drawing of three set of HZJ series excitation transformers.

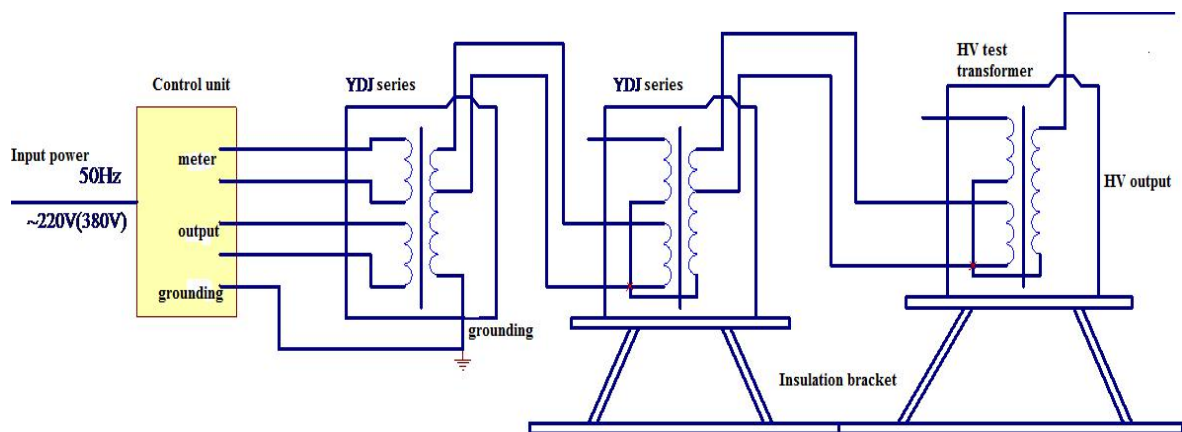

Explanation:

Control unit will provide power to the primary test winding, at the same time, the end and crust of primary high frequency voltage winding touches the floor, the head will be connected with high frequency voltage's end and its crust of the secondary test transformer. The primary series excitation switch provides power to the secondary low frequency voltage excitation winding. The same principal can be applied into the tertiary, the output voltage of the tertiary test transformer is the voltages sum of these three test

transformer, that's to say, $U(\text{sum}) = u_1 + u_2 + u_3$, at the same time, the capacity relationship is $S(\text{sum})=s_3 \times 3$.

3.4 HZJZ will form the direct current series excitation test transformer, but we need to add $2\sqrt{2}$ u silicon stack into the test transformer which is the highest frequency voltage after exchange series excitation.

1. Test transformer should be applied into use with control unit, as for how to use control unit, please see Operation Manual of Control unit.

2. Screening wire should be applied into the direct current test to avoid straying leakage. After test, discharge rod is applied to release the restored electricity.

3. The end of high frequency voltage filtering capacitance should be connected with the ground wire, together with crust of control unit to connect with the earth wire.

4. The whole test should follow the regulation in high frequency voltage test site, should pay more attention to the safety of equipment and body.

HZXC HV Hipot Control Unit

Control Box($\leq 10\text{KVA}$)

If the capacity of main control box is not more than 10KVA the panel of the main control box is as figure 4.



Figure 4 Panel of main control box

The operation of the insulation test with HZJ series HIPOT tester is as follow:

- 1) Please make grounding connection for sample object, HV transformer and main control box first
- 2) Please discharge the sample object if the sample object is a capacitive equipment.
- 3) Please make connection for tester and sample object according to figure 3.
- 4) Please make power connection for main control box.
- 5) Confirm the high voltage value in withstand.
- 6) Setting the protection value of current by the pointer on the over current protection relay panel.
- 7) Adjust the regulator to zero position and then press down the close button on the

panel the tester with enable the high voltage output unit.

- 8) If the regulator is not at zero position when you press down the close button the high voltage output unit would not be enabled. There is a zero position indication lighter on the panel of the main control box.
- 9) Adjust the high voltage output to the withstand test value step by step. Read the high voltage value and LV current from meters at the same time.
- 10) Start the timer by the timer switcher on the main control box panel when the high voltage has.
- 11) If the current over the value set on the panel of the over current relay the tester would cut off the power supply of HV transformer immediately. It is said the test result is failure.
- 12) If the timer display value reach the set value the tester would have a sound alarm to inform operator that the withstand time is ok. If the tester has not start the over current protection unit before sound alarm it is said the test result is ok.
- 13) Open the power supply of HV transformer by press down the “open” button on the panel of the main control box when test is end.
- 14) Please discharge the high voltage circuit of sample equipment before remove off the cable connection of high voltage circuit.

Please do not start the test if some part of the tester had been destroyed.

HZTC HV Hipot Control Unit

I.Outline

HZTC series control station is a complete set of equipment of high voltage test transformer, it and the test transformer carry out resistance pressure and leakage test. This product is in according with electric industrial standard DL/T848.2-2004.

II.Main Characteristics

This series product has characteristics, such as beautiful appearance, small volume, light weight, simply operation and conveniently maintenance.

This series control station is consists of touch type voltage adjustor and circuit on control, measure and signal. After goes through work frequency power 230V/400V, adjust the output voltage of voltage adjustor(namely the input voltage of test transformer), then accept the required test high voltage(the pressure value which is tester), which work principle is as the follow drawing.

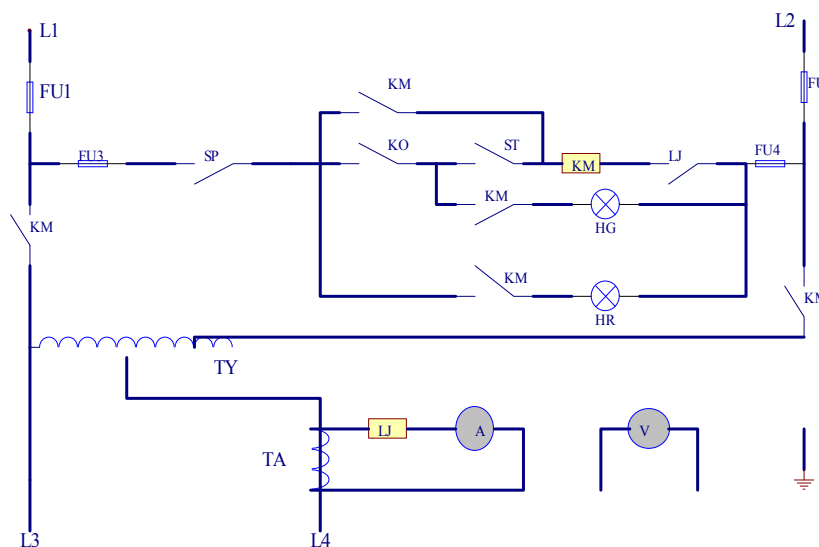

KM AC Touch Machine HG、HR Indicator TY Auto Voltage Adjustor
 LJ Current Relay TA Current Mutual Inductance KO Zero Switch

III.Panel Introduction

Series Controller($\geq 10\text{KVA}$)

If the capacity of main control box is over 10KVA the panel of the main control box is as following:

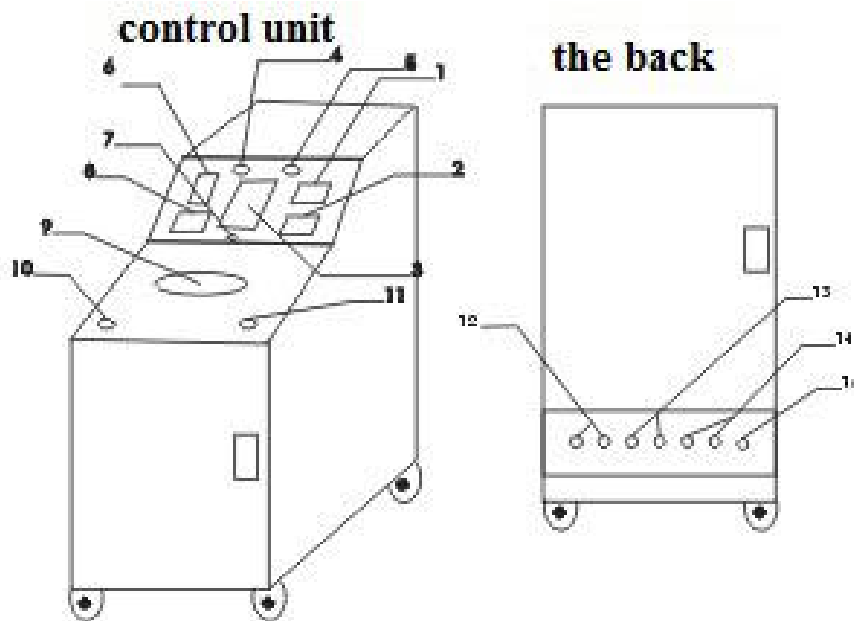

- 1、 HV voltmeter (KV) 2、 LV ammeter (A) 3、 Over current protection setup

- 4、 Power
- 5、 Operate
- 6、 Withstand voltage time setup
- 7、 Timer
- 8、 Over current protection ratio(×1, ×2,OFF)
- 9、 Handle of voltage regulator
- 10、 Start
- 11、 Stop
- 12、 Power Input 220V/380V
- 13、 Output 0~250V/430V
- 14、 Meter
- 15、 Grounding

IV.Technical Parameter

Model	Power			Output	
	Phase Value	Voltage (V)	Frequency (HZ)	Voltage (V)	Current (A)
HZTC-10	1/2	230/400	50	250/430	28/16.3
HZTC-15	2	380	50	430	23.3
HZTC-20	2	380	50	430	32.6
HZTC-30	2	380	50	430	46.5
HZTC-50	2	380	50	430	69.8

V.Connection Wire Sketch Drawing Of It And High Voltage Test Transformer

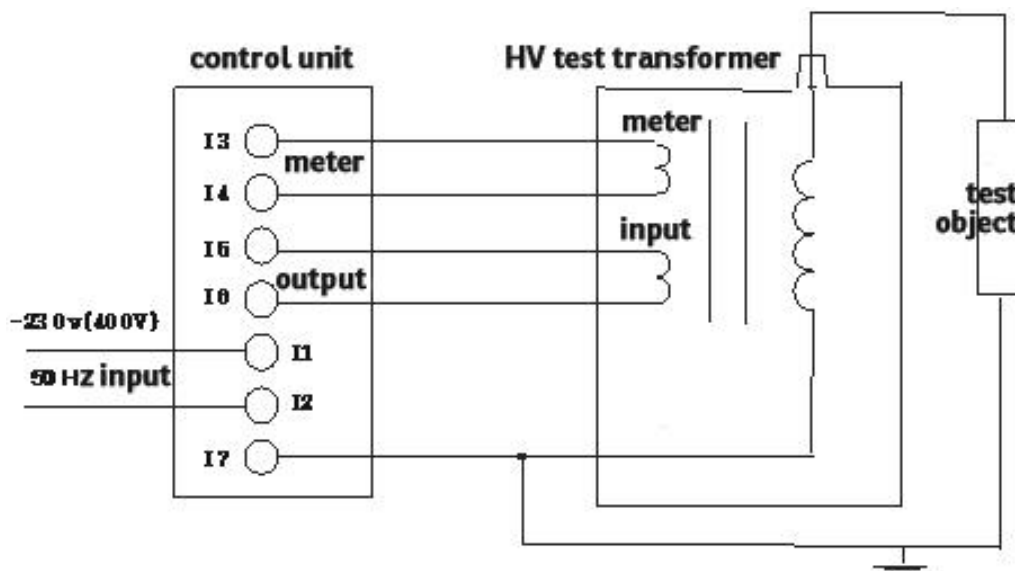

VI. Manual Explanation

1. As the table shows, please connect the control station with the test transformer, also please do not forget to connect with the floor line. After careful examination, you can make electricity go through it.

2. When the electricity goes through, please turn the voltage adjustor to Null, Zero Switch turns on and the signal turns on too(which indicate that the output of the voltage adjustor is Zero).

3. Press the Start Button, connect with touch machine, and plug the voltage adjustor in, at the same time, the power signal light will turn off, but working signal light will turn on.

4. Whirl the voltage adjustor slowly and clockwise, and read carefully the voltage meter, when it reaches the required voltage, please stop whirling and change the opposite direction to whirl until it reaches back to Zero.

5. After the examination, please press Stop Button, to shut off the touch machine, and the working signal light will turn off, but the Zero Signal Light will turn on.

6. This equipment is installed with over-current protection. Over-current relay should be chosen when you get the data by examination. But the relay always is setting to be 80% of the rated data. When it look a little over-loaded, please reset it according to the loaded current, to guarantee the safety of this equipment. During the voltage is becoming higher and higher, this experimental equipment will be proved not to be qualified if it becomes short-current, over-loaded relay, and the power were shut down. When it happens, you should whirl the adjustor to Zero Level.

VII. Usage And Maintenance

1. When you open the box, you need to check whether it's in good condition or not, especially you need to check whether the connection ports become loose or not, and the carbon brush connects with the voltage adjustor well or not.

2. Strictly follow the procedure, please read the manual first.

3. If it has been not in use for a long time, you should check main circuit floor insulating resistance by 2500V MΩ meter, and the data should not below 1.5MΩ.

VIII. Supplementary Explanation

HZTC series control station is another set of equipment of light test transformer, it has characteristics, perfect capacity, beautify appearance, small volume, light weight, beside, also has the function of switch on and timing, which manual explanation is same as TC control station.

1、 Over-current rated value= Over-current relay dial reading $\times K$

Among which, K is as a state value of change/excise (-SA) switch of current power, respectively for as 1, 2, ∞ ., K of the switch in $\times 1$ 、 $\times 2$ shift is as 1 and 2 respectively, excise shift is as $+\infty$ (in normal condition without using it to avoid damaging the equipment due to lost the protection for transformer.

2、 Electric control station is normally above 30KVA. As for client convenience, it adopts the methods of increasing voltage, decreasing voltage. The method of voltage increasing is same as manual, firstly fast, secondly slow. When the required voltage of increasing voltage is coming, don't press the button forever, it'd better loose a little (press and loose by turns). During the voltage decreasing, press the button of decreasing voltage until charcoal brush back to zero, then the zero signals light is on, you can press the button of stop. Finally, shut off the general switch (air switch).

3、 Panel drawing of control station and connection drawing, see the annex.

4、 This control station could measure the high voltage leak current of the tester. Please measure the high voltage leak current after accomplish the test of the AC voltage during in using to prevent occurring short circuit phenomenon and produce high voltage which exist dangers for operator. The specific procedure is as following:

First, connect the back connection board of the control station in specific wire, and then carry out the AC voltage test. Second, link the high voltage end part of the control station and test transformer (see the wiring sketch drawing in the next page) namely could read the value of the high voltage current.

IX. Electrical Schematic Diagram

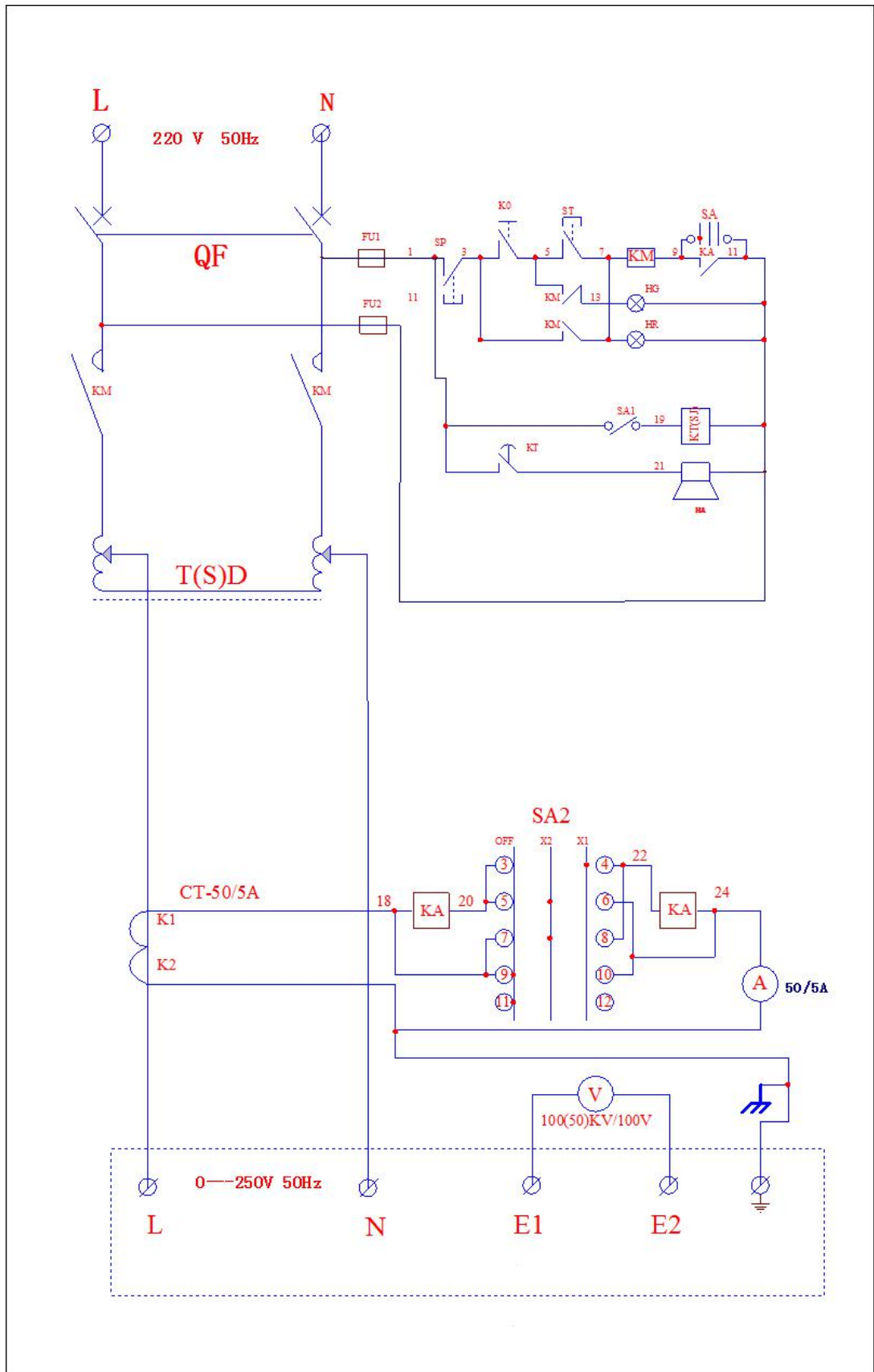

X.Packing List

No.	Item	Qty
1	Main engine	1
2	Control Box	1
3	Power line	1
4	Test line	1